

Dual Band Combiner (CBC)

Dual Diplexer Unit

850-2100 MHz

Model Number: DB-X-CBC-85-21

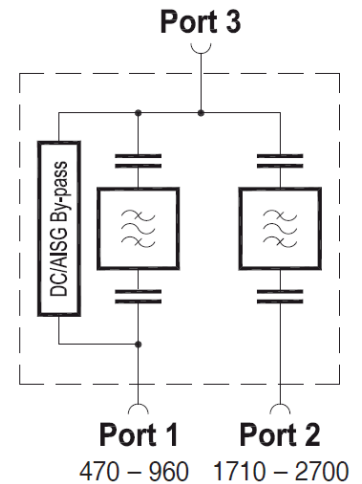

Main Features & Benefits:

- **Cavity Design, Designed for co-siting purposes, Supports DC/AISG Bypass.**
- **Available as a single unit for DAS, or a dual unit to support BTS tower structure.**
- **High Isolation - Can be used as a combiner near the BTS or in a reciprocal function near the antenna, enables feeder sharing, supporting antenna diversity.**
- **Very Low Passive Intermodulation(PIM) with Extremely low insertion loss.**
- **High out of band rejection level, Supporting GSM, LTE and WCDMA**
- **Compact design, Easy installation, Built-in lightning protection**
- **IP66 enclosure - Suitable for indoor or outdoor applications, Wall or mast mounting, Exceptional reliability and environmental protection.**
- **External DC Stop available as an accessory, High input power.**

Introduction

EMTS Telecom Services Ltd. Dual combiner model DB-X-CBC-85-21 is a high performance Cross Band Coupler (CBC) that use to combine BTS to a single antenna. The use of highly selective filters reduces the out of band inter-modulation products and minimize the interference to neighboring cells, high isolation level between ensuring an interference-free environment for any technology deployed. The EMTS innovative cavity filter design provides a very low insertion loss while keeping the product extremely compact and lightweight, Return Loss of more than 18dB makes the introduction of the device transparent to the BTS. The unit is designed to withstand the most severe outdoor environments. It's also features IP65 class protection to avoid any possible effects of condensation and pressure instability. Duplexers and Diplexers are unquestionably EMTS's core product line with success of designed features as high selectivity, high channel to channel isolation and extremely low insertion loss.



EMTS Telecom Services offers a comprehensive portfolio of enhanced coverage solutions for the Wireless Networks, Based on advanced technologies. **EMTS** proven, indoor and outdoor solutions solve a wide range of network challenges including interference and oscillation problems, challenging coverage holes, rapid response deployment and inadequate in-building coverage. Regardless of the technology or frequency, **EMTS** can provide customized coverage solutions that address any combination of unique and complex network needs for the Wireless Networks.

Technical Specifications - Dual-band dual unit

Radio specifications		
Frequency Band	Ch1: 470-960 MHz	CH2: 1710-2700 MHz
Insertion Loss	<0.2 dB	
Isolation Between port1&port2	>55 dB (470-960)/ >65 dB (1710-2700)	
VSWR	<1.2	
PIM(IM3)	<-160dBc@+2x43dBm	
DC/AISG transparency	Pass(max.2500mA)	stop
Input Power	250 watts per port	
Impedance	50Ω	
Environmental Specifications		
Temperature Range	-55 to +60°C	
Application	Outdoor IP66	
Operating Humidity	5-95%	
Lightning protection	3 kA, 10/350 us pulse	
Mechanical Specifications		
Connectors	DIN-Female(Long neck)	
Type	Cavity Type	
Color	Soft Grayish	
Weight	<2.5 kg	
Mounting Options	Pole & Wall	
Size (LxWxH)	170 x 145 x 138	

Ordering Information

Use Model No : DB-X-CBC-85-21

X = 1 for single branch type X=2 for dual branch type

About EMTS Telecom Services Ltd.:

EMTS is a leading supplier of high-quality RF coverage solutions designed to maximize wireless network coverage in difficult RF environments and complex settings. The company specializes in extending RF radio coverage to rural areas, office buildings, subways, tunnels and shadowed areas. The EMTS coverage solution supports all major mobile technologies and standards of wireless Networks.

All rights reserved

Note: All specifications subject to change without notice.



Mechanical Drawing

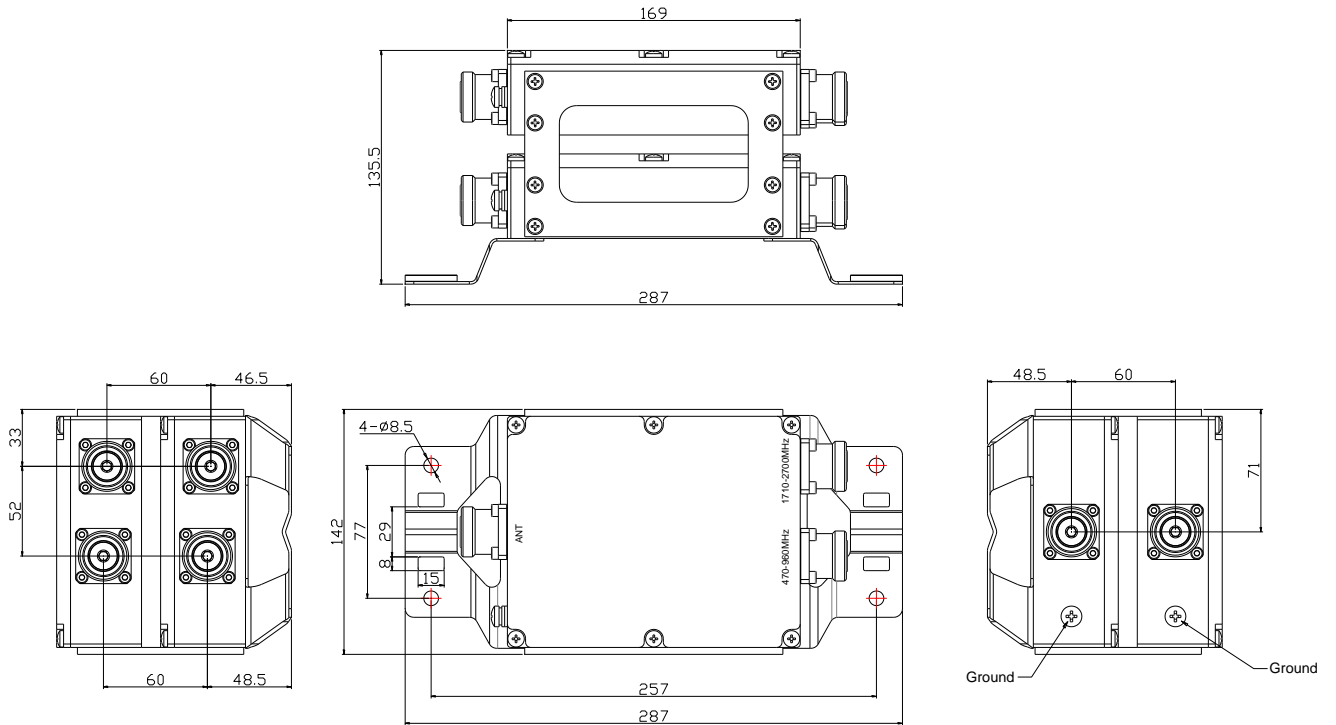

EMTS Telecom Services offers a comprehensive portfolio of enhanced coverage solutions for the Wireless Networks, Based on advanced technologies. **EMTS** proven, indoor and outdoor solutions solve a wide range of network challenges including interference and oscillation problems, challenging coverage holes, rapid response deployment and inadequate in-building coverage. Regardless of the technology or frequency, **EMTS** can provide customized coverage solutions that address any combination of unique and complex network needs for the Wireless Networks.