

TMB 800 MHz Multi Carrier High Power Outdoor Boosting System

Model No: TMB-M-800-O-51W15



Features:

- Employed best advanced pre-distortion and feed-forward technology
- Support multi-carrier LTE (FDD) with high system efficiency
- 120W Downlink output power, supports multi-carrier amplifier.
(Lower / higher Power types are also available)
- Support flexible downlink input either duplexed or un-duplexed
- Support system full diversity, Supports Japan 800 LTE bands
- Downlink and uplink gain adjustable with wide dynamic range
- Lower uplink noise figure
- Comprehensive product monitoring and control (local and remote);
- Centralized system control/display/alarms, Great system reliability supported by architecture built-in redundancy (Optional)
- All Models available operating power of 220/110VAC or -48VDC
- Extensive protection for lightning, voltage surge,
- Compact system size and light weight

Introduction

Wireless operators have used multi-carrier power amplifiers (MCPA) to increase the coverage and capacity of existing base stations. The use of MCPA has increased operator revenues without the excessive costs of adding or swapping out equipment and with no need to build additional cell sites.

The Multi-Carrier High Power Booster system provides higher downlink EIRP and improved uplink sensitivity at the same time to extend the coverage of existing networks.

This multi-carrier based product platform can also work with customized BTS to extend capacity of original BTS with a low system total cost. Our MCPA product line (Tower-Mounted and Floor-Mounted) provides cost effective network coverage extension and capacity upgrade solution.

The multi-carrier based product platform can also work with customized BTS to extend capacity of original WCDMA BTS with a low system total cost. The unit is also available for different Cellular bands: GSM, DCS, PCS & UMTS and support multi-carrier GSM/EDGE, LTE, and WCDMA signals, with mixed mode.



EMTS Telecom Services Ltd. offers a comprehensive portfolio of enhanced coverage solutions for the Wireless Networks. Based on advanced technologies. **EMTS** proven, indoor and outdoor solutions solve a wide range of network challenges including interference and oscillation problems, challenging coverage holes, rapid response deployment and inadequate in-building coverage. Regardless of the technology or frequency, **EMTS** can provide customized coverage solutions that address any combination of unique and complex network needs for the Wireless Networks.

Technical Specification

| Electrical Specifications | | |
|---|----------|---|
| Frequency range | Uplink | 832 – 862 MHz Optional Japan band 815 – 830 or 830 – 845 MHz |
| | Downlink | 791 - 821 MHz Optional Japan band 860 - 875 or 875 - 890 MHz |
| Output power | Uplink | ≥12dBm & Output IP3 (max gain) >23 dBm |
| | Down | 51 ±1dBm (Lower or Higher Power types are also available) |
| Gain | Uplink | 15±1dB |
| | Downlink | 15±1dB |
| Max Input Power | | 43dBm |
| Ways numbers | | 2 inputs, 2 outputs |
| Supporting Carriers / way | | 2/4/8 carriers |
| Bypass insertion loss | | ≤2.0dB |
| Input / output voltage standing wave ratio | | ≤1.5 |
| Uplink noise figure | | ≤ 2dB |
| Downlink intermodulation attenuation Spurious emission | | -55dBc typ. |
| | | ≤-36dBm @9KHz-1GHz |
| | | ≤-30dBm @1G-12.75GHz |
| | | ≤-47dBm @ 825-835MHz |
| | | ≤-47dBm @870-880MHz |
| | | ≤-47dBm @1800-1920MHz |
| Gain adjustment range | | ≤-98dBm @885-915MHz |
| Gain adjustment range | | 15dB |
| Band fluctuations | | < +/-1dB Gain Variation Over Temp < +/-1dB |
| Load mismatch against | | 10:1 |
| Power supply | | AC220V±20% , 45~55Hz |
| Mechanical Specifications | | |
| Dimensions (L * W * H) (mm) | | 730*440*330 |
| Net weight (kg) | | 45 |
| Gross weight (kg) | | 50 |
| Cooling | | Forced air cooling |
| Input and output impedance | | 50Ω |
| Environmental Specifications | | |
| Operating temperature | | -40°C to 55°C |
| Humidity | | ≤95% |
| Protection class | | IP66 |



About EMTS Telecom Services Ltd.:

EMTS is a leading supplier of high-quality RF coverage solutions designed to maximize wireless network coverage in difficult RF environments and complex settings. The company specializes in extending RF radio coverage to rural areas, office buildings, subways, tunnels and shadowed areas. The EMTS coverage solution supports all major mobile technologies and standards of wireless Networks. All rights reserved - Specifications are subject to change without notice

Note: All specifications subject to change without notice.

Technical Specification (Cont.)

| Monitoring features | |
|---------------------------|---|
| Local / remote monitoring | Local: DB-9 RS232 serial port Remote: Wireless MODEM via SMS (SMS) |
| Others Specifications | |
| EMC | ETS 300 342-3 |
| Lightening | IEC-1312-1 |
| Connectors | For RF7/16 DIN female / For Alarm pull push mail |
| MTBF | 100,000 hours |

Diagram of TMB System

Figure 1: Single-MCPA System (Outdoor)

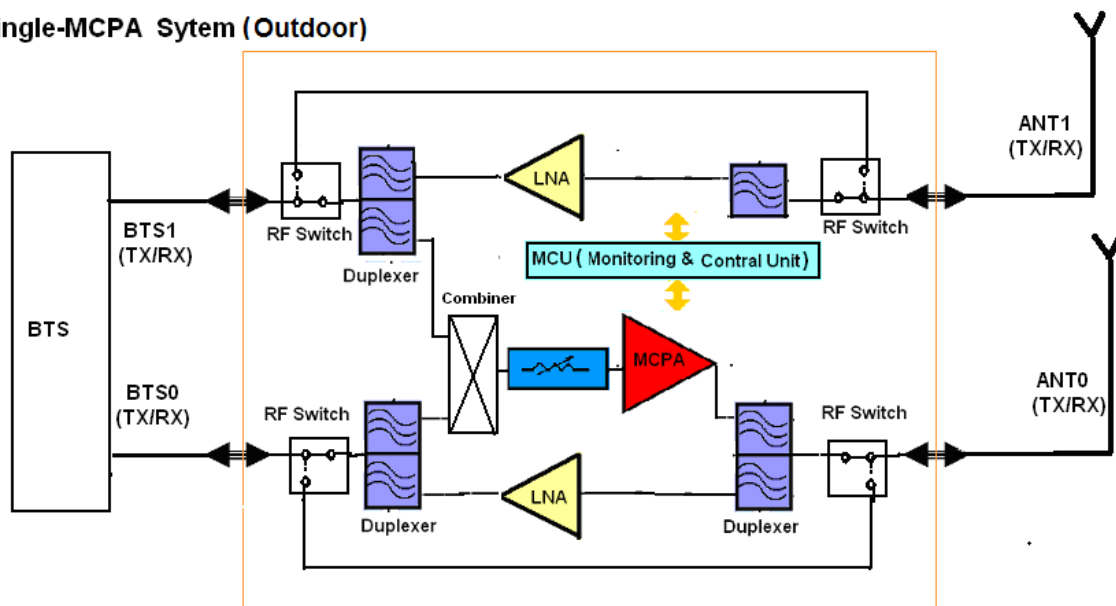

Ordering Information:

For full band cellular use Model No: TMB-M-800-O -50W15



About EMTS Telecom Services Ltd.:

EMTS is a leading supplier of high-quality RF coverage solutions designed to maximize wireless network coverage in difficult RF environments and complex settings. The company specializes in extending RF radio coverage to rural areas, office buildings, subways, tunnels and shadowed areas. The EMTS coverage solution supports all major mobile technologies and standards of wireless Networks. All rights reserved - Specifications are subject to change without notice

Note: All specifications subject to change without notice.