

# DCS 1800 MHz Antenna Combiner

**Model Number: EMTS-AC-1800-2B**

## Main Features & Benefits

- Two (TX/RX) inputs, one output to the antenna, Supports GSM & LTE standards.
- Supports 2 frequency blocks\*
- High Isolation
- Extremely low insertion loss
- High out of band rejection level.
- Compact design –employed advance filter technology
- Exceptional reliability and environmental protection – IP65
- DC Bias Port .

\*Frequencies are just for example -can be set to any combination

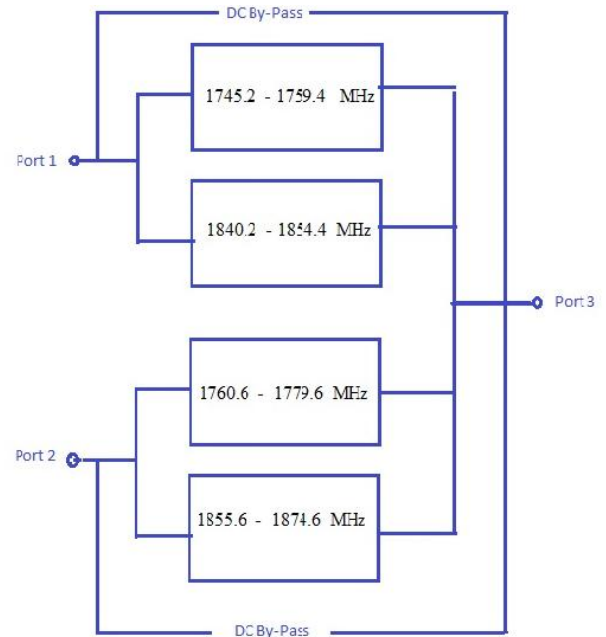

## Introduction

EMTS Telecom Services Ltd. 1800 (DCS) Combiner model EMTS- AC-1800-2B is a high performance TX/RX Filter that allows the use BTS in dense RF area where the frequency band is fragmented . The usage of highly selectivity filters reduce the out of band inter-modulation products and minimize the interference to neighbor cells, high isolation level between ensuring an interference-free environment for any technology deployed.

The EMTS innovative cavity & dielectric filter design provides a very low insertion loss while keeping the product extremely compact and lightweight, Return Loss of min 18dB makes the introduction of the device transparent to the BTS. The unit is designed to withstand the most severe outdoor environments. It's also features IP65 class protection to avoid any possible effects of condensation and pressure. instability. Duplexers and Diplepers are unquestionably EMTS's core product line with success of designed features as high selectivity, high channel to channel isolation and extremely low insertion loss.



EMTS Telecom Services offers a comprehensive portfolio of enhanced coverage solutions for the Wireless Networks, on advanced technologies. EMTS proven, indoor and outdoor solutions solve a wide range of network ges including interference and oscillation problems, challenging coverage holes, rapid response deployment and late in-building coverage. Regardless of the technology or frequency, EMTS can provide customized coverage ns that address any combination of unique and complex network needs for the Wireless Networks.

## Technical Specifications

### 1.1 Electrical Specifications

Item		Specifications
Frequency range	Input Port 1 *	1745.2-1759.4MHz (UL)
		1840.2-1854.4MHz (DL)
	Input Port 2*	1760.6-1779.6MHz (UL)
		1855.6-1874.6MHz (DL)
	Out Port*	1745.2-1759.4MHz (UL)
		1840.2-1854.4MHz (DL)
		1760.6-1779.6MHz (UL)
		1855.6-1874.6MHz (DL)
Insertion loss (dB)		1.5dB
Isolation		28dB
VSWR		≤1.2
IMD3		≤-145dBC
Impedance		50Ω
Handling Power		≥150W

\*Frequencies are just for example -can be set to any combination

### 1.2 Environmental Specifications

Operating Temperature	- 40 to 65 Celsius Degress
Standard	Outdoor use, IP65
Surge Protection	3KA(10/350us)
RoHS	2011/65/EU
Temperature Range(°C)	-20 to +70
Humidity (%)	0 to 100 %
Environmental rating	IP67

### 1.3 Mechanical Specifications

Installation	Wall or Mast
Connector Type	D-Female
Dimension(mm)	400x250x90
Weight (Kg)	About 7kg
Inner contact Plating	Silver
Out contact Plating	trimetal
Connectors:	DIN 7/16 (F), DIN 7/16, (F)
Mounting Options	Pole & Wall or System
Size(mm)	200 x 75 x 55

#### How To order:

Use model No: AC-1800-2B-X1 -X2-Y1-Y2

X1 = Downlink CF block 1, X2 = Downlink CF block 2

Y1=Bandwidth Block 1, Y2=Bandwidth Block 2

#### About EMTS Telecom Services Ltd.:

EMTS is a leading supplier of high-quality RF coverage solutions designed to maximize wireless network coverage in difficult RF environments and complex settings. The company specializes in extending RF radio coverage to rural areas, office buildings, subways, tunnels and shadowed areas. The EMTS coverage solution supports all major mobile technologies and standards of wireless Networks.

All rights reserved

Note: All specifications subject to change without notice.

